

# MARQUIS<sup>®</sup> SERIES



## INSTALLATION AND USER GUIDE

### Retrophone<sup>™</sup> Desk Series and Wall Mount Series

#### FEATURES

- Retro Looking Design
- One Line
- DTMF Tone Dialing
- Handset Volume Control Button
- Desk or Wall Mount Versions Available
- Fully Modular, Easy To Install



## INTRODUCTION

Congratulations on the purchase of your TeleMatrix Retrophone™ telephone. The Retrophone™ telephone is designed the Retrophone™ telephone to be simple to install and easy to use. Please be sure to read this user's guide to become familiar with the wiring and functionality of this product.

As specified by FCC regulation, we are required to inform you of specific governmental and compliance regulatory requirements, safety notices, safety instructions and other informative information. TeleMatrix, Inc. provides this information in a separate manual that is packed within each outer box or product box when shipped.

Prior to reading this operation manual and prior to setting up your telephone, please refer to the Compliance and Safety Manual. If you cannot locate this guide, download the document using the web site [www.telematrixusa.com](http://www.telematrixusa.com) or contact TeleMatrix Inc directly by telephone.

## COMPLIANCE AND SAFETY



# CONTENTS

---

Definition of Controls .....	1
Features and Parts List .....	2
Installation .....	3
Switch Settings .....	4
Operation .....	5
Care and Maintenance .....	7
Service .....	8
Warranty .....	9



# DEFINITION OF CONTROLS

1. Handset ..... Hearing aid compatible, low profile styling.
2. Handset Volume Control .... Adjusts the loudness of the receiver volume when pressed.
3. Handset Jack ..... Modular receptacle where handset cord plugs into the base unit.
4. Dial Pad ..... Large keys used for dialing.
5. Ringer Controls ..... Adjusts the volume of the ringers to ON/OFF setting.

DESK MOUNT VERSION

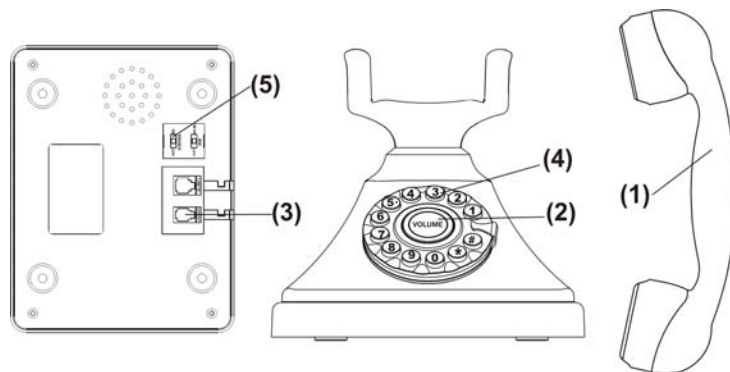

WALL MOUNT VERSION

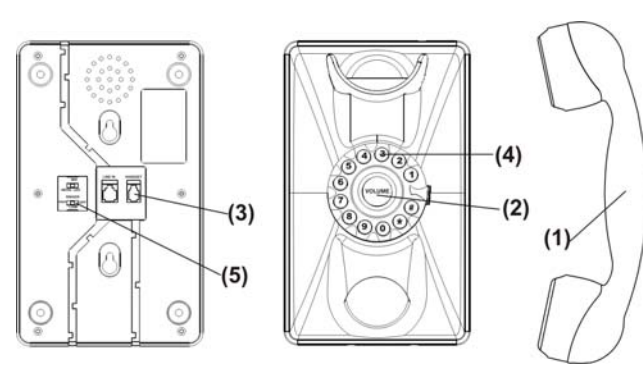

## FEATURES

- Retro Looking Design
- One Line
- DTMF Tone Dialing
- Handset Volume Control Button
- Desk or Wall Mount Versions Available
- Fully Modular, Easy To Install

## PARTS LIST

The following parts are included in this package:

1. 15-foot 4P4C modular telephone line cord
2. 10-foot Modular coiled handset cord
3. 3-inches 6p4c wall mount line
4. Base unit
5. Handset

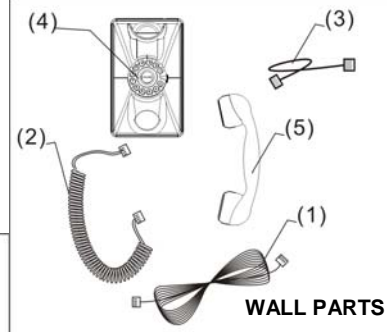
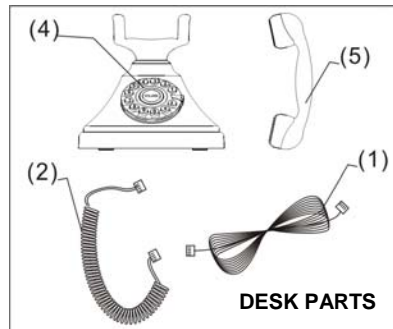

Figure 1

# INSTALLATION

## Connecting The Handset Cord

A 10-foot modular coil handset cord is provided. To install, simply plug one end of the handset cord into the modular jack on the handset. The remaining end of the handset cord plugs into the jack labeled "Handset" located on the back side of the base unit. (figure 2)

## Connecting The Line Cord

A 15-foot modular line cord is provided. To install, simply plug one end of the line cord into the modular jack located on the back of the base unit. The remaining end of the line cord plugs into the wall jack. (figure 3)

### CAUTION:

- Never install telephone wiring during a lightning storm.
- Never install telephone jacks in wet locations unless the jack is specifically designed for wet locations.
- Never touch uninstalled telephone wires or terminals unless the telephone line has been disconnected at the network interface.
- Use caution when installing or modifying telephone lines.

Figure 2

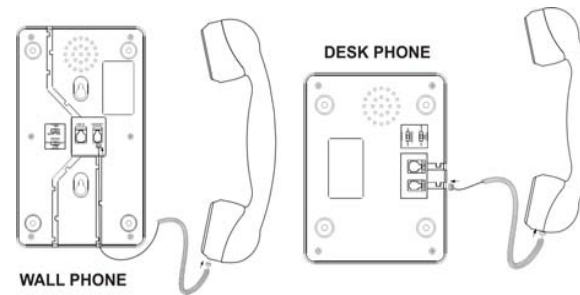
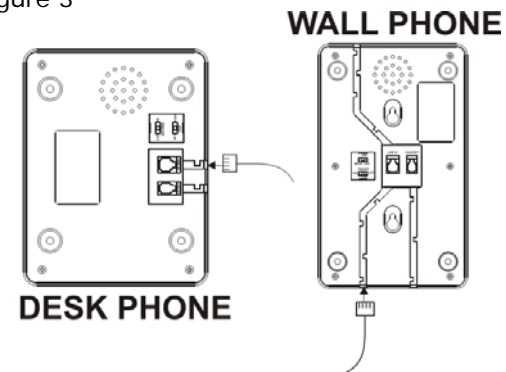

Figure 3



# SWITCH SETTINGS

## Ringer Volume Switch

A ringer volume switch is located on the side of the Retrophone™ telephone base (wall mount version) or the back side of the telephone (desk mount version). Ringer volume selections are ON or OFF. (figure 4)

Figure 4

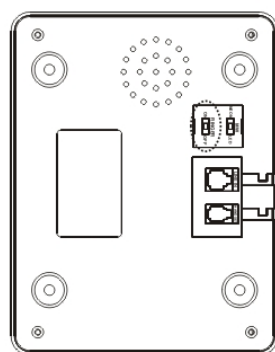

**DESK PHONE**

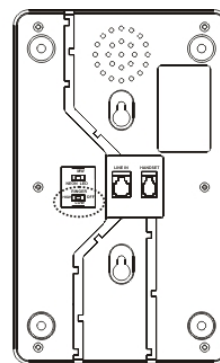

**WALL PHONE**

## OPERATION

### **Placing a Call using the Handset**

Lift the handset. Dial out by using the numeric dial pad.

### **Receiving a Call using the Handset**

Lift the handset when ringing.

### **Handset Volume Control**

The handset volume control increases the volume of the handset.

When the handset is off hook, press the volume control button to increase the handset volume. The volume control button has UP and DOWN arrows to increase or decrease the volume. The volume can be adjusted in eight steps.  
(figure 5)

The Retrophone is ADA hearing aid compatible (12dB—15 dB).



Figure 5

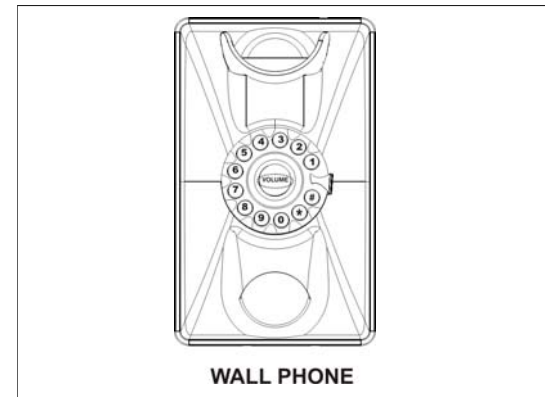



# CARE AND MAINTENANCE

---



Keep the telephone dry. If it gets wet, wipe it dry immediately. Liquids might contain minerals that can corrode the electronic circuits.



Use and store the telephone only in normal temperature environments. Temperature extremes can shorten the life of electronic devices, damage batteries, and distort or melt plastic parts.



Keep the telephone away from excessive dust and dirt that can cause premature wear of parts.



Wipe the telephone with a damp cloth occasionally to keep it looking new. Do not use harsh chemicals, cleaning solvents, or strong detergents to clean the system.

# SERVICE

When problems arise during installation or service that cannot be resolved using this or related documents, contact the TeleMatrix Technical Service department 8:30a.m. - 4:30p.m. MST:

Toll Free: 1-800-462-9446

Direct: 719-638-8821

Fax: 719-638-8815

[www.telematrixusa.com](http://www.telematrixusa.com)

Many times a problem is either installation or user related. Please contact TeleMatrix PRIOR to sending a telephone to our service center for repair. In the unlikely event that a factory repair be necessary:

1. Include a brief description of the trouble that you are experiencing.
2. Include a proof of purchase for a repair under warranty.
3. Send the telephone prepaid by UPS or Parcel Post insured to:

TeleMatrix, Inc.  
Customer Care Center  
5025 Galley Road  
Colorado Springs, CO. 80915

TeleMatrix will pay to return the repaired telephone to you.  
Allow 2-3 weeks for delivery.

# WARRANTY

## STATEMENT OF LIMITED WARRANTY

TeleMatrix, Inc. (TMX) warrants to its [original end customer] [purchaser] that Spectrum, Spectrum Plus and Marquis branded products manufactured by TMX are free from defects in materials and workmanship for five (5) years after the date of purchase, and Regency branded products manufactured by TMX are free from defects in materials and workmanship for three (3) years, other than the following products for which the warranty period shall be one (1) year: handset batteries, either NiCd or NiMH, used in TMX cordless products. If a product fails this warranty during the warranty period, TMX will, at its option, either repair or replace the defective product or parts, or deliver replacements for defective products or parts on an exchange basis at no additional charge to the customer except as set forth below. Repair parts or replacement products may be either new or reconditioned. Products or parts returned to TMX under this warranty will become the property of TMX. Warranties on products repaired by TMX expire at the termination of the original warranty period.

This limited warranty does not cover:

1. Products or parts which are damaged, abused or misused;
2. Any damage resulting from improper installation, maintenance or operation of the product;
3. Damage resulting from unauthorized modification or repair of the product, or from improper connection of the product to other equipment;
4. Cords, connectors and replaceable batteries;
5. Damage in transit to the TMX repair facility;
6. Any product or part unless proof of date of purchase is submitted with the product when returned for warranty repair; or
7. Costs incurred by the customer in removing and shipping the product to TMX for repair or replacement, and costs of reinstallation of the product.
8. Products or parts which are not owned and used by the original end user customer.

The cost and risk of loss or damage for sending the product to TMX will be borne by the customer.

TMX EXPRESSLY DISCLAIMS ALL WARRANTIES EXCEPT THE LIMITED WARRANTY SET FORTH HEREIN, WHICH IS THE SOLE AND EXCLUSIVE WARRANTY OF THE PRODUCT, AND IS IN LIEU OF ALL OTHER WARRANTIES, WHETHER ORAL OR WRITTEN, EXPRESS OR IMPLIED, OR STATUTORY. THERE ARE NO IMPLIED WARRANTIES OF MERCHANTABILITY OR FITNESS FOR A PARTICULAR PURPOSE. THE CUSTOMER'S SOLE REMEDY UNDER THE TMX WARRANTY SHALL BE REPAIR OR REPLACEMENT AS PROVIDED ABOVE. IN NO EVENT WILL TMX BE LIABLE TO CUSTOMER OR ANY OTHER PARTY FOR ANY INDIRECT, INCIDENTAL OR CONSEQUENTIAL DAMAGES, INCLUDING, WITHOUT LIMITATION, DAMAGES OF LOST PROFITS, LOST REVENUES, LOSS OF USE OF FACILITIES OR EQUIPMENT, OR COST OF SUBSTITUTE EQUIPMENT ARISING OUT OF THE USE OR INABILITY TO USE THIS PRODUCT, EVEN IF THE CUSTOMER HAS ADVISED TMX OF THE POSSIBILITY OF SUCH DAMAGES. TMX LIABILITY FOR DAMAGES SHALL NOT EXCEED THE PURCHASE PRICE OF THE DEFECTIVE PRODUCT.

This limited warranty is non-transferable without the prior written approval of TMX. It gives the customer specific legal rights. The customer may have other rights which vary under local law. Some jurisdictions may not allow limitations on the term of an implied warranty or exclusions or limitations of incidental or consequential damages.