

MARQUIS[®] SERIES
.....
FROM TELEMATRIX

INSTALLATION AND USER GUIDE

**3002MWD
TWO LINE
DELUXE FEATURE
SPEAKERPHONE
5 or 10 MEMORY**



TeleMatrix Copyright 2005 ©





COMPLIANCE AND SAFETY

As specified by FCC regulation, we are required to inform you of specific governmental and compliance regulatory requirements, safety notices, safety instructions and other informative information. TeleMatrix, Inc. provides this information in a separate manual. We pack the separate Compliance and Safety Manual within each outer box or product box when shipped.

Prior to reading this operation manual and prior to setting up your telephone, please refer to the Compliance and Safety Manual.



If the Compliance and Safety Manual is not immediately available. Please obtain a free copy by calling our Priority Care Department (phone number 1-800-462-9446) or by downloading a copy on our Internet (web site address www.telematrixusa.com).





CONTENTS

Features	1
Controls	2
Switch Settings	4
Installation	5
Wall Mounting	7
Programming Speed Dial Memory	8
Operation	11
Care and Maintenance	16
Service	17
Warranty	18





FEATURES

- Two Line
- Convenient Data Port
- 5 or 10 Single Button Memory Locations With Secure Programming
- Tone Dialing
- Speaker Key
- Conference Key
- Mute Key
- Handset Volume Control
- TouchLite™ Message Waiting Retrieval
- Store Key (submerged))
- Storable Flash Function Programmable at 100mS to 1000mS (default is 600mS)
- Storable Pause Function Programmable at 1.0 to 5.0 Seconds (default is 1.2 Seconds)
- HI/LOW Ringer Volume Control Switch
- Desk or Wall Mountable
- Fully Modular, Easy To Install

CONTROLS

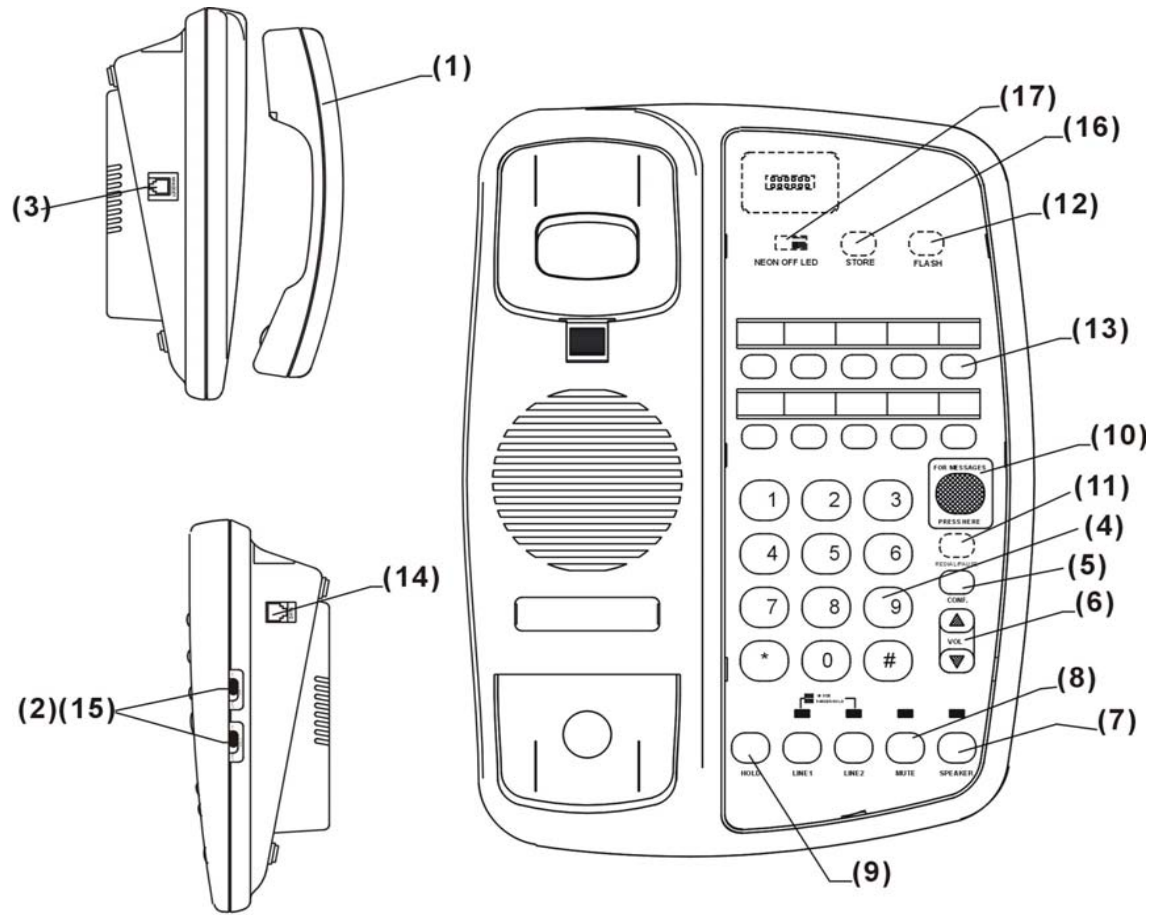

FRONT VIEW

DEFINITION OF CONTROLS

- | | |
|--|--|
| 1. Handset | Hearing aid compatible, low profile styling. |
| 2. Ringer Controls | Adjusts the volume of the ringers to HI/LOW setting. |
| 3. Handset Jack | Modular receptacle where handset cord plugs into the base unit. |
| 4. Dial Pad | Large keys used for dialing. |
| 5. Conference Key | Used for conference calling. |
| 6. Handset Volume Control | Controls the loudness of the receiver volume when pressed. |
| 7. Speaker Key | Used to activate speaker |
| 8. Mute Key | Used to mute speaker key and handset |
| 9. Hold Key | Used to place caller on hold |
| 10. Message Waiting TouchLite™ Key | Used to call voice mail to retrieve messages. |
| 11. Pause Key | (Submerged Key) Used to program a 1.2 second pause in memory. |
| 12. Flash Key | (Submerged Key) Used to provide a 600 mS line break to access PBX/Centrex. |
| 13. Feature Access Keys | 5 or 10 Programmable memory locations (based on model) for frequently dialed phone numbers and access codes. |
| 14. Data Port | Used to connect a computer modem, fax machine, or answering device. |
| 15. High/Low Ringer Volume Switch | Used to control the ringing volume for each line. |
| 16. Store Key | (Submerged Key) Used to program information for speed dialing. |
| 17. Message Waiting Lamp Switch | Used to select the Message Waiting Light operation. |

SWITCH SETTINGS

There are installer selectable switches located on the bottom base underneath a protective plastic overlay. These switches are hidden behind a plastic cover for security. To locate, remove the plastic covers using a sharp pointer or paper clip as shown.

Message Waiting Selector

The 3002MWD can support 90VDC neon or low-voltage LED message waiting systems. Simply slide the switch to the desired position that is compatible with your PBX messaging system.

Note: the phone is factory preset to the "Neon" setting.

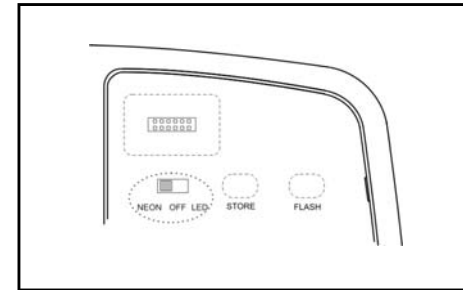

Line Voltage Selectors (Optional Feature)

The 3002MWD is designed to operate behind PBX telephone systems rated between 24 volts and 48 volts. If you have this feature, there are line voltage selector switches that must be set according to the PBX system rating that the phone will be installed. There are two (2) switches, the first for Line 1 and the other for Line 2. Each switch has three (3) setting options. They are: "24V/48V/OFF". Set the switches by simply sliding to the appropriate setting. The "OFF" setting is used to turn off the line if a line appearance is not wired to the telephone.

Note: the factory default is set to the "24V" setting.

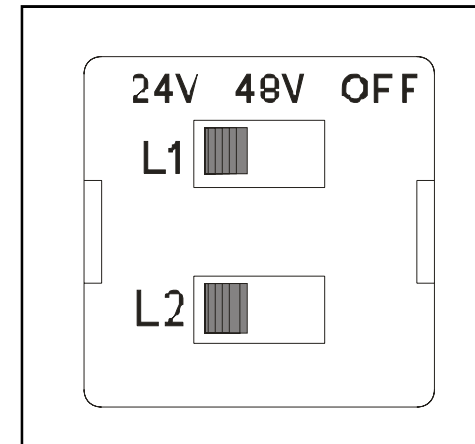

INSTALLATION

Parts Check List

The following parts are included in this package:

1. 15' modular telephone line cord.
2. Modular coiled handset cord.
3. Base unit
4. Handset

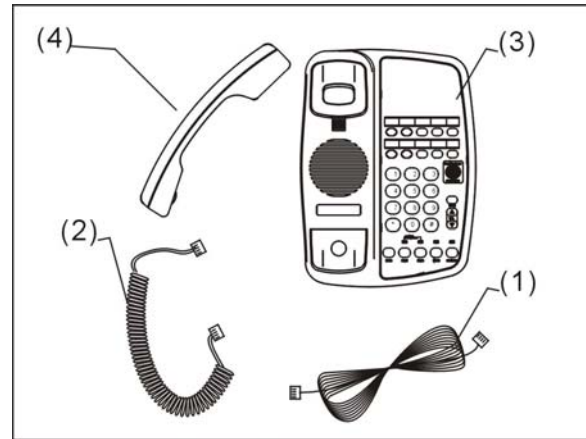

Caution

- Never install telephone wiring during a lightning storm.
- Never install telephone jacks in wet locations unless the jack is specifically designed for wet locations.
- Never touch uninstalled telephone wires or terminals unless the telephone line has been disconnected at the network interface.
- Use caution when installing or modifying telephone lines.

The wall mount wedge and short line cord parts are not included. Call customer service for assistance.

INSTALLATION

Connecting The Handset Cord

A 10' modular coil handset cord is provided. To install, simply plug one end of the handset cord into the modular jack on the handset. The remaining end of the handset cord plugs into the jack labeled "Handset" located on the left side of the base unit. (figure 3)

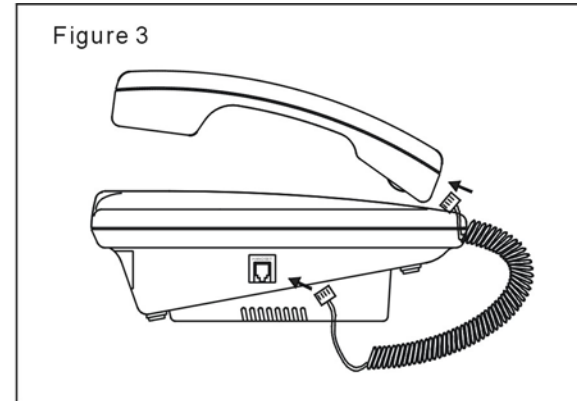

Connecting The Line Cord

A 15' modular line cord is provided. To install, simply plug one end of the line cord into the modular jack located on the back of the base unit. The remaining end of the line cord plugs into the wall jack. (figure 4)

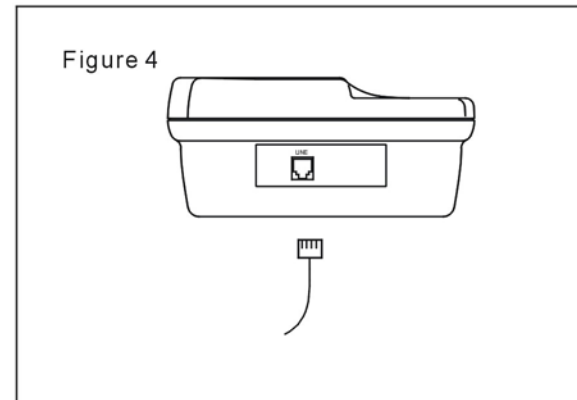

WALL MOUNTING

Wall Mounting (OPTIONAL)*

The Marquis Telephone was designed to be conveniently wall mounted. There is no additional hardware required. Follow these easy steps:

1. The handset retaining clip must be engaged to secure the handset when hanging up. To engage the clip, unsnap the clip, rotate the clip 180° and then snap the clip into place. (figure 7)
2. Plug one end of a short line cord (not included) into the line jack on the back of the Marquis base unit. Plug the remaining end of the short line cord into the wall jack.
3. Next, snap in the wall mount wedge (not included) and guide the phone onto the studs of the wall jack. Pull down firmly until you feel it snap into place. The unit is now wall mounted. (figure 8)

CONTACT TELEMATRIX FOR THE OPTIONAL WALL MOUNTING WEDGE. CALL PRIORITY CARE AT 1-800-462-9446.

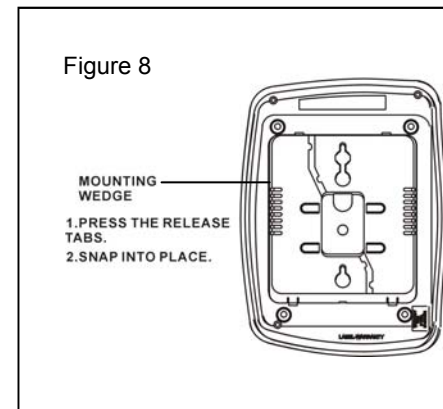
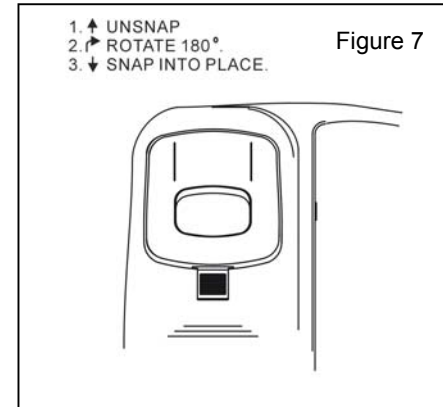

PROGRAMMING SPEED DIAL

The **"STORE"**, **"FLASH"**, and **"PAUSE"** function keys are located underneath the clear plastic overlay and paper faceplate. To access, lift off the overlay and paper faceplate using a paperclip or sharp pointer. (figure 9 and 10)

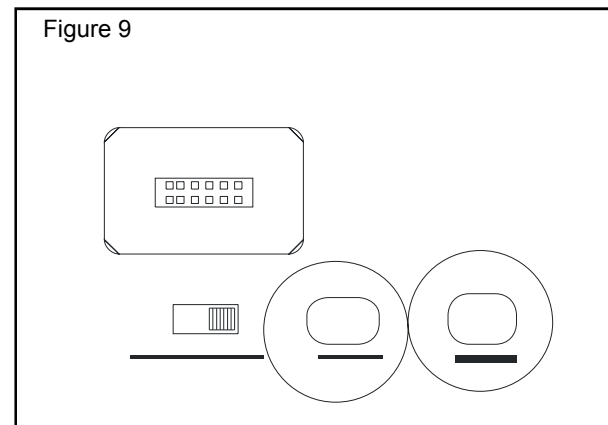
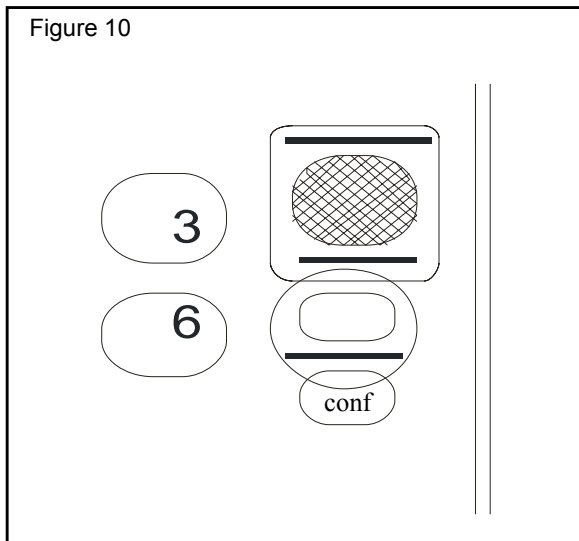

PROGRAMMING SPEED DIAL

Storing A Number Into Memory

Up to 10 phone numbers can be stored into memory. Each location can store up to 32 digits in tone mode .

Note: a "PAUSE" or "FLASH" programmed into memory counts as one digit when storing a number.

1. Select Line 1.
2. Lift the handset.
3. Press the STORE key.
4. Enter the numbers to be stored using the numeric dial pad.
5. Press the desired memory location wherein the number is to be stored.
6. If additional numbers are to be stored, repeat steps 4 thru 5.
7. Hang up the handset.

Storing "PAUSE" Into Memory

If you are using your 3002MWD anywhere that requires an access code for outside calls, you may need to add a "PAUSE" to the number to allow time for the outside line to connect. You can enter as many pauses as needed.

Note: a "PAUSE" or "FLASH" programmed into memory counts as one digit when storing a number.

1. Select Line 1.
2. Lift the handset.
3. Press the STORE key.
4. Enter the required access code using the numeric dial pad.
5. Press the "PAUSE" key.
6. Enter the digits to be stored using the numeric dial pad.
7. Press the desired memory location wherein the number is to be stored.
8. If additional numbers are to be stored, repeat steps 4 thru 7.
9. Hang up the handset.

FLASH Hook Function

The Flash function is used to access PBX features or Telco line features such as Call Waiting. The FLASH function is a 600mS timed line beak. If the FLASH function will be used often, store the feature into memory location for easy access as follows:

1. Lift the handset then press the "STORE" key.
2. Press the "FLASH" key.
3. Press the memory location wherein the "FLASH" is to be stored.
4. Hang up the handset.

PROGRAMMING THE *TouchLite*™

Feature Description

TouchLite is a new innovation that integrated the visual message waiting lamp and a speed dial key into one. It allows easy access for guests to retrieve messages.

When the message waiting lamp lights to notify the guest that a message is waiting, a simple press of the RED TouchLite connect the guest to the message center or front desk.

TouchLite also adds an additional memory location to this telephone. (6 to 11 total speed dial memories depending on the model)

Programming TouchLite™

1. Select line 1
2. Lift the handset.
3. Press the "STORE" key.
4. Enter the numbers to be stored using the numeric dial pad.
5. Press the red TouchLite key to store.
6. Hang up the handset.
(figure 9 and 10)

OPERATION

Handset Volume Control

The handset volume control increases the volume of the handset.
When the handset is off hook, press the volume control key to increase the handset volume.
The volume control is a HI/LOW operation and is hearing aid compatible.

Ringer Volume Control

The ringer volume control increases the volume of the ringer.
There are individual switches for line 1 and line 2.
The volume control options are HI or LOW for each line.

Using The Data Port

The phone is equipped with a convenient port on the right side of the base unit. This modular receptacle is used to plug in any standard telephone device such as a computer modem, answering machine or fax machine.

OPERATION

Line Status Indicators

The Marquis Telephone is equipped with LED indicators to show the current status of the telephone lines. They are:

- Ringing Line—Ringing LED turns red on incoming ringing signal.
- Line IN USE—Line status LED lights green when line is IN USE.
- HOLD—Line status LED turns from green to red when placing a call on hold. All remote extensions will light red.

Placing a Call Using the Handset

- Press the line 1 or line 2 key that does not show a line IN USE indication.
- Lift the handset.
- Dial out by using the numeric dial pad or by pressing a speed dial location.

Receiving a Call Using the Handset

- When the phone rings, the ring indicator will light red to show which line is ringing.
- Select the line key for the line that is ringing and lift the handset.

OPERATION

Using the Conference Key

The "Conference" key is used to establish a 3- way conversation. The conference feature is activated by a "soft" key that will automatically reset when hanging up.

A 3-way "Conference" call can be established while using either the handset or Speakerphone. To use the "Conference" feature:

1. Place the line that is currently in-use on hold by pressing the "Hold" key. The line status indicator will turn from Green to Red.
2. The second call can be established by selecting the idle line key and dialing the call.
3. When the second call is established, activate the 3-way conference call by pressing the "Conference" key. Line 1 and Line 2 will automatically "bridge"together and all the three parties can now converse.
4. To end the call, simply hang-up by placing the handset back in its cradle (on-hook) or by pressing the "Speaker" key.
5. If you wish to continue speaking with one of the callers and wish to "drop" the other caller, simply press the line key of the caller you wish to continue speaking with. The other caller will automatically drop-off.

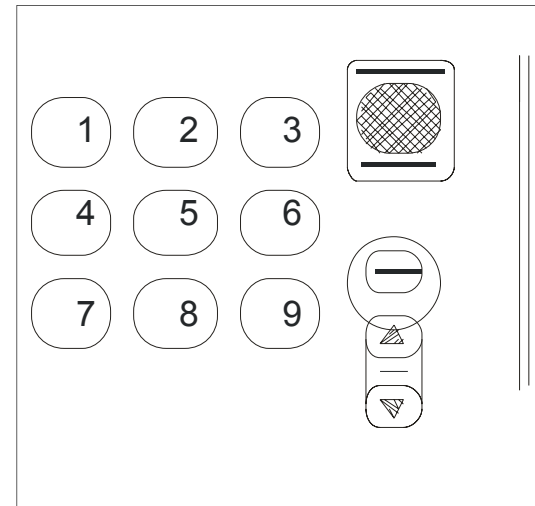

OPERATION

Placing A Call Using The Speakerphone

The 3002MWD is equipped with a high quality speakerphone feature to allow for hands free operation. To use, simply press the "Speaker On/Off" key when placing or answering a call. The telephone line will activate automatically. The "Speaker" key will light up indicating that the speakerphone is in-use. To hang-up, press the "Speaker On/Off" key again.

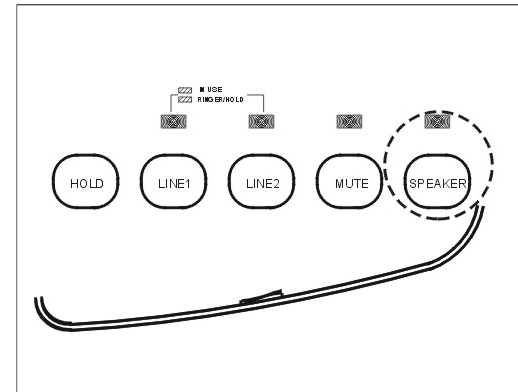

Using The Mute Feature

A "Mute" key is provided to allow privacy during a background conversation. When the "Mute" key is activated, the microphones in the handset and the speakerphone are disabled. When the "Mute" feature is activated, the caller will not hear your voice. The "Mute" key will light to show that the feature is activated. To de-activate, press the "Mute" key again.

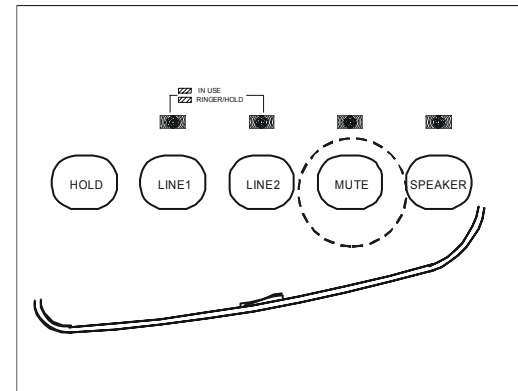

OPERATION

Using The Hold Feature

The "Hold" key is used to place a caller on hold. To use, simply press the "Hold" key. The key will illuminate indicating that the line is on hold.

When placing a caller on hold, the handset can be returned to its on hook position. The line will not be disconnected. To return to the caller, lift the handset and press the line key.

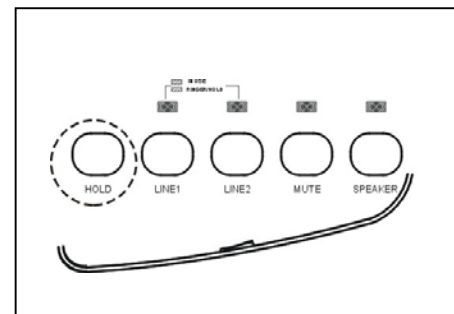

CARE AND MAINTENANCE



Keep the telephone dry. If it gets wet, wipe it dry immediately. Liquids might contain minerals that can corrode the electronic circuits.



Use and store the telephone only in normal temperature environments. Temperature extremes can shorten the life of electronic devices, damage batteries, and distort or melt plastic parts.



Keep the telephone away from excessive dust and dirt that can cause premature wear of parts.



Wipe the telephone with a damp cloth occasionally to keep it looking new. Do not use harsh chemicals, cleaning solvents, or strong detergents to clean the system.

SERVICE

When problems arise during installation or service that cannot be resolved using this or related documents, contact the TeleMatrix Technical Service department 8:30a.m. - 4:30p.m. MST:

Toll Free: 1-800-462-9446
Direct: 719-638-8821
Fax: 719-638-8815
www.telematrixusa.com

Many times a problem is either installation or user related. Please contact TeleMatrix PRIOR to sending a telephone to our service center for repair. In the unlikely event that a factory repair be necessary:

1. Include a brief description of the trouble that you are experiencing.
2. Include a proof of purchase for a repair under warranty.
3. Send the telephone prepaid by UPS or Parcel Post insured to:

TeleMatrix, Inc.
Customer Care Center
5025 Galley Road
Colorado Springs, CO. 80915

TeleMatrix will pay to return the repaired telephone to you. Allow 2-3 weeks for delivery.

WARRANTY

STATEMENT OF LIMITED WARRANTY

TeleMatrix, Inc. LLC (TMX) warrants to its [original end customer] [purchaser] that Spectrum, Spectrum Plus and Marquis branded products manufactured by TMX are free from defects in materials and workmanship for five (5) years after the date of purchase, and Regency branded products manufactured by TMX are free from defects in materials and workmanship for three (3) years, other than the following products for which the warranty period shall be one (1) year: hand-set batteries, either NiCd or NiMH, used in TMX cordless products. If a product fails this warranty during the warranty period, TMX will, at its option, either repair or replace the defective product or parts, or deliver replacements for defective products or parts on an exchange basis at no additional charge to the customer except as set forth below. Repair parts or replacement products may be either new or reconditioned. Products or parts returned to TMX under this warranty will become the property of TMX. Warranties on products repaired by TMX expire at the termination of the original warranty period.

This limited warranty does not cover:

1. Products or parts which are damaged, abused or misused;
2. Any damage resulting from improper installation, maintenance or operation of the product;
3. Damage resulting from unauthorized modification or repair of the product, or from improper connection of the product to other equipment;
4. Cords, connectors and replaceable batteries;
5. Damage in transit to the TMX repair facility;
6. Any product or part unless proof of date of purchase is submitted with the product when returned for warranty repair; or
7. Costs incurred by the customer in removing and shipping the product to TMX for repair or replacement, and costs of reinstallation of the product.
8. Products or parts which are not owned and used by the original end user customer.

The cost and risk of loss or damage for sending the product to TMX will be borne by the customer.

TMX EXPRESSLY DISCLAIMS ALL WARRANTIES EXCEPT THE LIMITED WARRANTY SET FORTH HEREIN, WHICH IS THE SOLE AND EXCLUSIVE WARRANTY OF THE PRODUCT, AND IS IN LIEU OF ALL OTHER WARRANTIES, WHETHER ORAL OR WRITTEN, EXPRESS OR IMPLIED, OR STATUTORY. THERE ARE NO IMPLIED WARRANTIES OF MERCHANTABILITY OR FITNESS FOR A PARTICULAR PURPOSE. THE CUSTOMER'S SOLE REMEDY UNDER THE TMX WARRANTY SHALL BE REPAIR OR REPLACEMENT AS PROVIDED ABOVE. IN NO EVENT WILL TMX BE LIABLE TO CUSTOMER OR ANY OTHER PARTY FOR ANY INDIRECT, INCIDENTAL OR CONSEQUENTIAL DAMAGES, INCLUDING, WITHOUT LIMITATION, DAMAGES OF LOST PROFITS, LOST REVENUES, LOSS OF USE OF FACILITIES OR EQUIPMENT, OR COST OF SUBSTITUTE EQUIPMENT ARISING OUT OF THE USE OR INABILITY TO USE THIS PRODUCT, EVEN IF THE CUSTOMER HAS ADVISED TMX OF THE POSSIBILITY OF SUCH DAMAGES. TMX LIABILITY FOR DAMAGES SHALL NOT EXCEED THE PURCHASE PRICE OF THE DEFECTIVE PRODUCT.

This limited warranty is non-transferable without the prior written approval of TMX. It gives the customer specific legal rights. The customer may have other rights which vary under local law. Some jurisdictions may not allow limitations on the term of an implied warranty or exclusions or limitations of incidental or consequential damages.



252-0277-3(3002MWD)
Rev May 2, 2005

