

MARQUIS[®] SERIES
.....
FROM TELEMATRIX

INSTALLATION AND USER GUIDE

2800MWB
SINGLE LINE
BASIC FEATURE
TELEPHONE



TeleMatrix Copyright 2005 ©





COMPLIANCE AND SAFETY

As specified by FCC regulation, we are required to inform you of specific governmental and compliance regulatory requirements, safety notices, safety instructions and other informative information. TeleMatrix, Inc. provides this information in a separate manual. We pack the separate Compliance and Safety Manual within each outer box or product box when shipped.

Prior to reading this operation manual and prior to setting up your telephone, please refer to the Compliance and Safety Manual.

If the Compliance and Safety Manual is not immediately available. Please obtain a free copy by calling our Priority Care Department (phone number 1-800-462-9446) or by downloading a copy on our Internet (web site address www.telematrixusa.com).





CONTENTS

Features	1
Controls	2
Installation	4
Switch Settings	6
Wall Mounting	7
Operation	8
Care and Maintenance	9
Service	10
Warranty	11





FEATURES

- One Line
- Convenient Data Port
- Neon/LED Message Waiting Lamp Switch
- Tone Dialing
- Handset Volume Control
- HI/LOW Ringer Volume Control Switch
- Desk or Wall Mountable
- Fully Modular, Easy To Install

CONTROLS

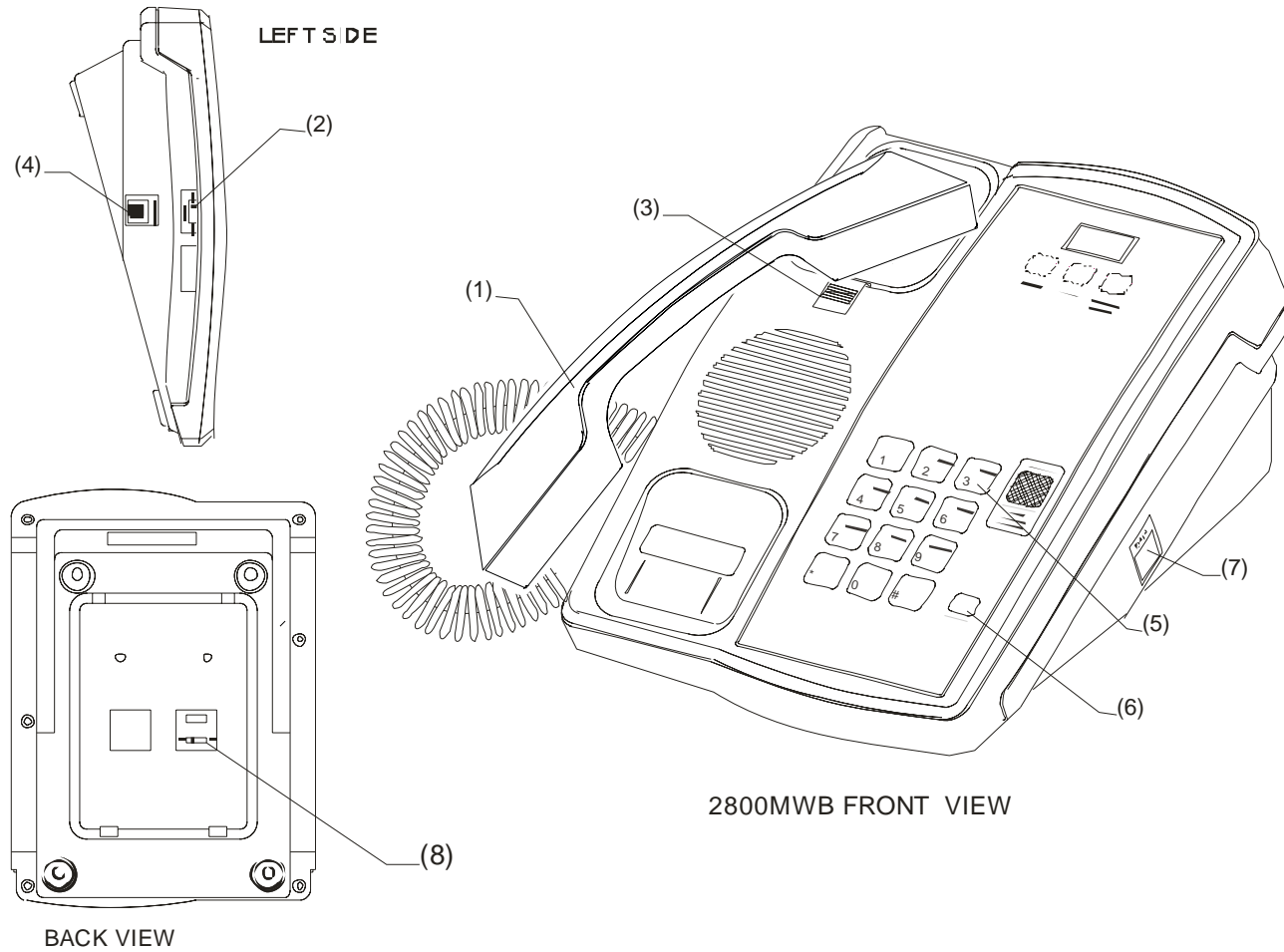

DEFINITION OF CONTROLS

1. Handset Hearing aid compatible, low profile styling.
2. Ringer Controls Adjusts the volume of the ringers to HI/LOW setting.
3. Handset Clip Retains the handset when the phone is wall mounted.
4. Handset Jack Modular receptacle where handset cord plugs into the base unit.
5. Dial Pad Large keys used for dialing.
6. Handset Volume Control Increase the loudness of the receiver volume when pressed.
7. Data Port Used to connect a computer modem, fax machine, or answering device.
8. Message Waiting Selector Switch Select optional 90VDC or Low voltage LED Message Waiting.

INSTALLATION

Parts Check List

The following parts are included in this package:

1. 15' modular telephone line cord.
2. Modular coiled handset cord.
3. Base unit
4. Handset

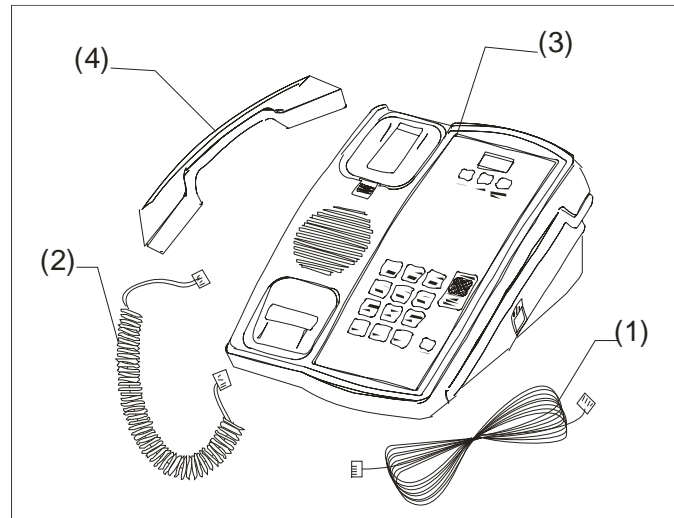

Caution

- Never install telephone wiring during a lightning storm.
- Never install telephone jacks in wet locations unless the jack is specifically designed for wet locations.
- Never touch uninstalled telephone wires or terminals unless the telephone line has been disconnected at the network interface.
- Use caution when installing or modifying telephone lines.

Parts not included wall mount wedge. Call customer service for wall mount wedge. @ 800 462 9446

INSTALLATION

Connecting The Handset Cord

A 10' modular coil handset cord is provided. To install, simply plug one end of the handset cord into the modular jack on the handset. The remaining end of the handset cord plugs into the jack labeled "Handset" located on the left side of the base unit. (figure 3)

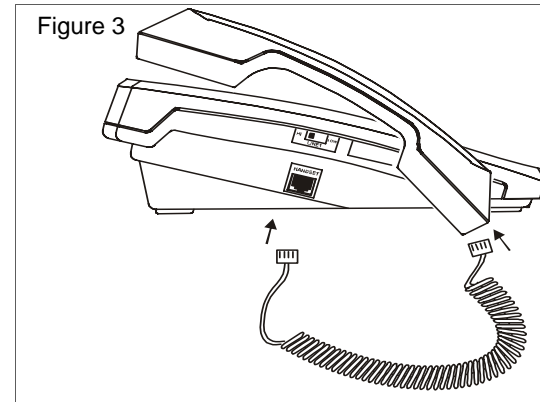

Connecting The Line Cord

A 15' modular line cord is provided. To install, simply plug one end of the line cord into the modular jack located on the back of the base unit. The remaining end of the line cord plugs into the wall jack. (figure 4)

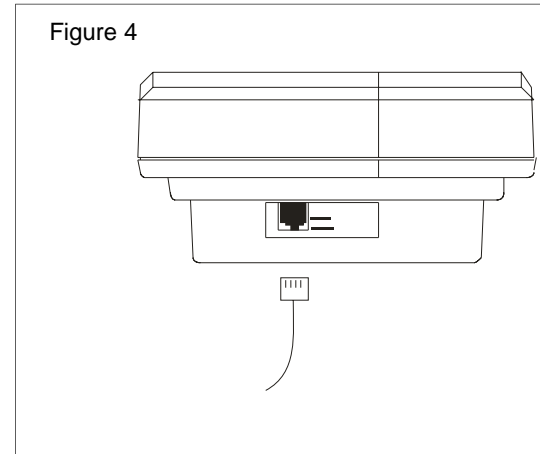

SWITCH SETTINGS

There are installer selectable switches located on the bottom of the base unit. These switches are hidden behind a plastic cover for security. To locate, remove the plastic covers using a sharp pointer or paper clip as shown.

Message Waiting Selector

The 2800MWB can support 90VDC neon or low-voltage LED message waiting systems. Simply slide the switch to the desired position that is compatible with your PBX messaging system.

Note: the phone is factory preset to the "Neon" setting.

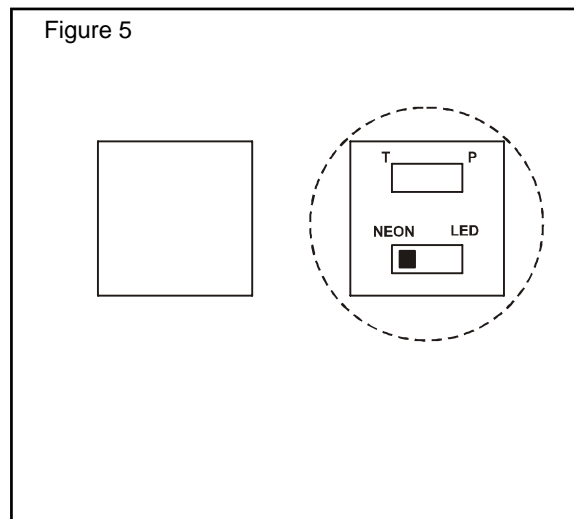

WALL MOUNTING

Wall Mounting Your 2800MWB

The 2800MWB was designed to be conveniently wall mounted. Follow these easy steps:

1. The handset retaining clip must be engaged to secure the handset when hanging up. To engage the clip, unsnap the clip, rotate the clip 180° and then snap the clip into place. (figure 7)
2. Plug one end of a short line cord (not included) into the line jack on the back of the base unit. Plug the remaining end of the short line cord into the wall jack.
3. Snap in the optional wall mount wedge (not included) onto the base (figure 8). Once attached to the phone base, then guide the phone onto the studs of the wall jack. Pull down firmly. The unit is now wall mounted.

1. ↑ UNSNAP
2. ↻ ROTATE 180°.
3. ↓ SNAP INTO PLACE.

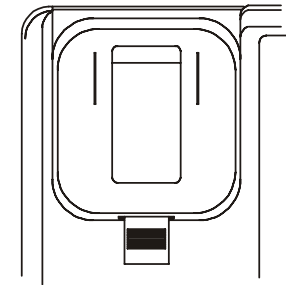

Figure 7

Figure 8



OPERATION

A. PLACING A CALL USING THE HANDSET

- Lift the handset.
- Dial out by using the numeric dial pad or by pressing a speed dial location.

B. RECEIVING A CALL USING THE HANDSET

- lift the handset when ringing.

HANDSET VOLUME CONTROL

The handset volume control increases the volume of the handset.

When the handset is off hook, press the volume control key to increase the handset volume. The volume control is a HI/LOW operation. It is hearing aid compatible.

CARE AND MAINTENANCE



Keep the telephone dry. If it gets wet, wipe it dry immediately. Liquids might contain minerals that can corrode the electronic circuits.



Use and store the telephone only in normal temperature environments. Temperature extremes can shorten the life of electronic devices, damage batteries, and distort or melt plastic parts.



Keep the telephone away from excessive dust and dirt that can cause premature wear of parts.



Wipe the telephone with a damp cloth occasionally to keep it looking new. Do not use harsh chemicals, cleaning solvents, or strong detergents to clean the system.

SERVICE

When problems arise during installation or service that cannot be resolved using this or related documents, contact the TeleMatrix Technical Service department 8:30a.m. - 4:30p.m. MST:

Toll Free: 1-800-462-9446
Direct: 719-638-8821
Fax: 719-638-8815
www.telematrixusa.com

Many times a problem is either installation or user related. Please contact TeleMatrix PRIOR to sending a telephone to our service center for repair. In the unlikely event that a factory repair be necessary:

1. Include a brief description of the trouble that you are experiencing.
2. Include a proof of purchase for a repair under warranty.
3. Send the telephone prepaid by UPS or Parcel Post insured to:

TeleMatrix, Inc.
Customer Care Center
5025 Galley Road
Colorado Springs, CO. 80915

TeleMatrix will pay to return the repaired telephone to you. Allow 2-3 weeks for delivery.

WARRANTY

STATEMENT OF LIMITED WARRANTY

TeleMatrix, Inc. (TMX) warrants to its [original end customer] [purchaser] that Spectrum, Spectrum Plus and Marquis branded products manufactured by TMX are free from defects in materials and workmanship for five (5) years after the date of purchase, and Regency branded products manufactured by TMX are free from defects in materials and workmanship for three (3) years, other than the following products for which the warranty period shall be one (1) year: handset batteries, either NiCd or NiMH, used in TMX cordless products. If a product fails this warranty during the warranty period, TMX will, at its option, either repair or replace the defective product or parts, or deliver replacements for defective products or parts on an exchange basis at no additional charge to the customer except as set forth below. Repair parts or replacement products may be either new or reconditioned. Products or parts returned to TMX under this warranty will become the property of TMX. Warranties on products repaired by TMX expire at the termination of the original warranty period.

This limited warranty does not cover:

1. Products or parts which are damaged, abused or misused;
2. Any damage resulting from improper installation, maintenance or operation of the product;
3. Damage resulting from unauthorized modification or repair of the product, or from improper connection of the product to other equipment;
4. Cords, connectors and replaceable batteries;
5. Damage in transit to the TMX repair facility;
6. Any product or part unless proof of date of purchase is submitted with the product when returned for warranty repair; or
7. Costs incurred by the customer in removing and shipping the product to TMX for repair or replacement, and costs of reinstallation of the product.
8. Products or parts which are not owned and used by the original end user customer.

The cost and risk of loss or damage for sending the product to TMX will be borne by the customer.

TMX EXPRESSLY DISCLAIMS ALL WARRANTIES EXCEPT THE LIMITED WARRANTY SET FORTH HEREIN, WHICH IS THE SOLE AND EXCLUSIVE WARRANTY OF THE PRODUCT, AND IS IN LIEU OF ALL OTHER WARRANTIES, WHETHER ORAL OR WRITTEN, EXPRESS OR IMPLIED, OR STATUTORY. THERE ARE NO IMPLIED WARRANTIES OF MERCHANTABILITY OR FITNESS FOR A PARTICULAR PURPOSE. THE CUSTOMER'S SOLE REMEDY UNDER THE TMX WARRANTY SHALL BE REPAIR OR REPLACEMENT AS PROVIDED ABOVE. IN NO EVENT WILL TMX BE LIABLE TO CUSTOMER OR ANY OTHER PARTY FOR ANY INDIRECT, INCIDENTAL OR CONSEQUENTIAL DAMAGES, INCLUDING, WITHOUT LIMITATION, DAMAGES OF LOST PROFITS, LOST REVENUES, LOSS OF USE OF FACILITIES OR EQUIPMENT, OR COST OF SUBSTITUTE EQUIPMENT ARISING OUT OF THE USE OR INABILITY TO USE THIS PRODUCT, EVEN IF THE CUSTOMER HAS ADVISED TMX OF THE POSSIBILITY OF SUCH DAMAGES. TMX LIABILITY FOR DAMAGES SHALL NOT EXCEED THE PURCHASE PRICE OF THE DEFECTIVE PRODUCT.

This limited warranty is non-transferable without the prior written approval of TMX. It gives the customer specific legal rights. The customer may have other rights which vary under local law. Some jurisdictions may not allow limitations on the term of an implied warranty or exclusions or limitations of incidental or consequential damages.



252-0272-4 (2800MWB)
Revision June 1, 2005

